

## Lamprey Encoder Assembly Instructions

### Step 1 -- Inventory your kit

Take care to keep the sensor magnet away from other strong fields. Exposure to Neodymium style magnets can damage the target.

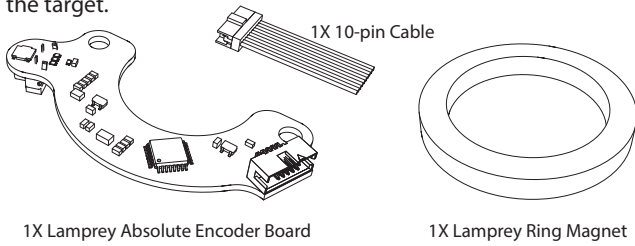

### Step 2 -- Mount The Sensor Board

The sensor should be as concentric as possible with the planned axis of rotation of the target magnet.

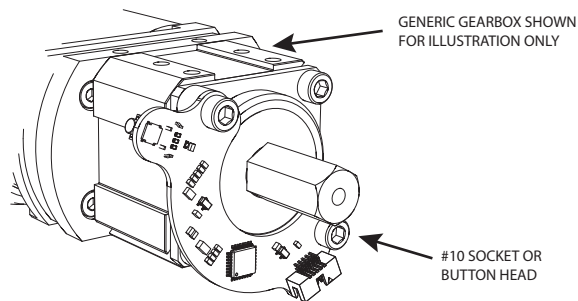

### Step 3 -- Install The Magnet

Install the magnet onto the device you wish to measure. Loctite 401 or similar quick setting glue is recommended.

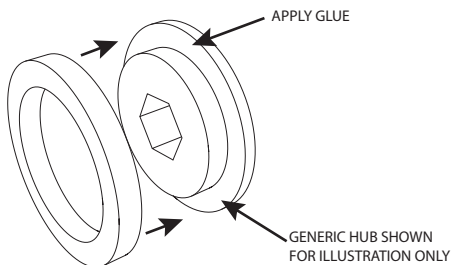

### Step 4 -- Set The Air Gap

The magnet can be no closer than 0.150" from the top surface of the board. The sensor will give meaningful results up till about 0.500" from the pcb surface, but closer is better. Air gaps outside of these ranges will cause the sensor to report incorrect angles.

The magnet may be placed on either side of the pcb and can be sensed through non-ferrous materials.

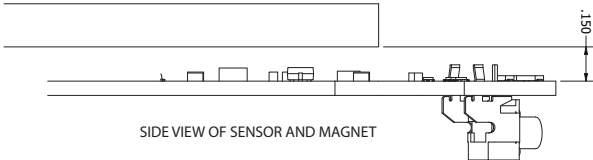

### Step 5 -- Install 10-pin IDC cable

This sensor requires 5v DC. If power is properly applied the always ON orange LED will light.

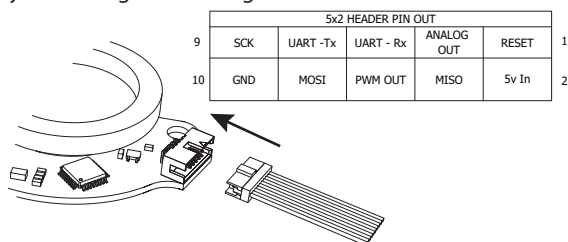

## Lamprey Encoder Calibration Instructions

### Step 6 -- Basic Sensor Calibration

To use the sensor and receive quality measurements you must complete a calibration once the board and magnet are properly installed. There is a basic and advanced option.

#### 6a -- Hold Either Button As You Power Up

This will force the sensor into calibration mode. The sensor will flash all three status LEDs in an ascending pattern. Release the button after the light sequence completes.

#### 6b -- Rotate The Magnet Slowly

Slowly rotate the magnet through at least three complete rotations. The LEDs are now acting as a signal strength indication. They will turn solid as stronger signals are recorded...all three LEDs solid is a maximum signal. At least the red LED solid is required.

**\*\*A flashing red LED indicates a failure and you should restart the procedure**

You have now finished the basic calibration...click either button once to finish. The sensor is now in 3.3v analog mode!

### Step 7 -- Advanced Sensor Calibration

To enter this mode do a double click at the end of step 6b.

Do an advanced calibration if you desire more precise angle outputs from the sensor. This step requires some careful inputs and is much easier if using the UART connection to view the debug messages from the sensor. During this step you'll align the sensor to known angles. The more precisely you align the output during this step the better your result will be. A fixture or other means for locking each angle into place is highly recommended.

1. Choose the number of calibration points desired. Each click of the button will cycle through the cal points menu. The LEDs will light to indicate the selected mode. Red = 8, Red+Green = 12, Red + Green + Blue = 24, Blue only = 36. More calibration points will yield a more linear and accurate angle measurement.

2. Do a long press to select your desired calibration. The LEDs will begin flashing.

3. Align your sensor output to an arbitrary zero position and click either button. After each successful click during this stage the LED's will flash a sequence to acknowledge that the point has been recorded.

4. Accurately rotate the sensor to your relative angle either CW or CCW, hold it in this position and press either button. The relative angle equals  $(360 \text{ degrees}) / (\text{number of cal points})$ . For an eight position cal your relative angle between points would be 45 degrees.

5. Repeat step 4. for the total number of cal points chosen.

**\*\*The sensor will only record points that are within a certain tolerance range...the sensor will quickly flash all the LEDs to indicate that you've attempted to select a point that is out of range.**

6. When complete the status LEDs will flash an ascending sequence and the sensor will wake into 3.3v analog output mode.

You should see the always on power LED and the blue LED illuminated. Any other LED indication means the calibration failed and you should restart.

### Setting New Zero Positions

To set a new zero position during normal operation press and hold either user button for one second.

The LEDs will flash to indicate a new setting.

The red LED will flash when you cross the zero point to offer a visual check of the programmed location.