

Pre-Assembly Steps

Tools needed: Allen wrench set, External snap ring plier, $\frac{3}{8}$ " wrench, $\frac{3}{4}$ " wrench, 10-24 tap

Step 1: Lay out all parts and confirm that all parts are in the kit and that you can identify the different parts. This will greatly reduce assembly time and help prevent assembly errors.

Step 2: Locate (4) Plastic Bottom Bushings. Tap with 10-24 tap through (2) holes in each bushing. (4) Bushings total.

Step 3: Locate (1) 6" Wheel. Tap with 10-24 tap x 0.75" deep (6) holes in each wheel. Mark on the wheel which side has been tapped.



1

Sub-Assembly 1 (SA1): Bottom Mounting Plate

Parts Used: (8) 10-24 x $\frac{3}{8}$ " Button Head Cap Screws (BHCS), (8) #10 aluminum washers, (4) Plastic Bottom Bushings, (1) Bottom Mounting Plate

Step 1: Assemble each Plastic Bottom Bushing to plate and fasten using (2) bolts and (2) washers as shown. Do not tighten completely, the radial positioning will be determined at later step. Repeat with remaining (3) Plastic Bottom Bushings.



Sub-Assembly 2 (SA2): Wheel Assembly

Parts Used: (1) 6" Wheel, (1) $\frac{1}{2}$ " hex bore Wheel Adapter, (6) 10-24 x $\frac{3}{4}$ " Button Head Cap Screws (BHCS)

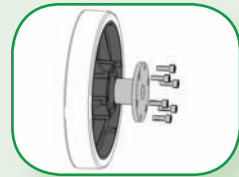

Step 1: Assemble Wheel Adapter into wheel and fasten using (6) 10-24 x $\frac{3}{4}$ " screws. Tighten all screws. Wheel adapter may require a light press.

Sub-Assembly 3 (SA3): Gearbox-Wheel Assembly

Parts Used: (2) Gearbox Sideplates, (4) $\frac{3}{8}$ " ID x $\frac{7}{8}$ " OD Flanged Ball Bearings, (2) $\frac{1}{2}$ " ID x $1\frac{1}{8}$ " OD Flanged Ball Bearings, (1) 14 tooth spur gear (A1), (2) 24 tooth spur gears with $\frac{3}{8}$ " hex bore or (B1) and (C1), (1) 35 tooth spur gear with $\frac{3}{8}$ " hex bore (A2), (1) 40 tooth spur gear with $\frac{3}{8}$ " hex bore or (B2), (1) 40 tooth spur gear with $\frac{1}{2}$ " hex bore or (C2), (1) 5" - $\frac{1}{2}$ " hex Drive Shaft, (2) 1.5" - $\frac{3}{8}$ " hex Gear Shaft, (3) $\frac{1}{2}$ " Retaining Rings, (1) Wheel Assembly, (2) Bearing Shims, (1) CIM Motor, (2) 10-32 x $\frac{1}{2}$ " BHCS, (1) 3 mm Shaft Key, (1) $\frac{5}{16}$ " Retaining Ring, (1) Gearbox Top Plate, (12) 10-24 x $\frac{3}{8}$ " Flat Head Cap Screws (FHCS), (1) $\frac{3}{8}$ " ID Rubber Grommet, (1) Outside Wheel Mount Plate, (1) Rotor

Step 1: Press (2) $\frac{3}{8}$ " ID Flanged Ball Bearings into (2) middle holes as shown.

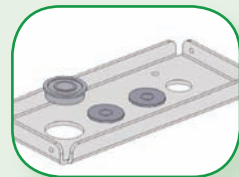
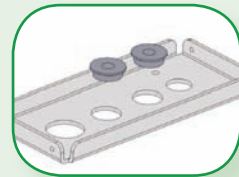

Step 2: Press (1) $\frac{1}{2}$ " ID Flanged Ball Bearing into position shown. This piece is now called "Outside Gearbox Sideplate".

2

AM GEAR SELECTION AND RATIOS

Gear Teeth				Ratio	RPM	Ft/Sec
A1 14	A2 35	0.40	0.03	31.89	86.24	2.26
B1 14	B2 50	0.28				
C1 14	C2 50	0.28				
A1 14	A2 35	0.40	0.05	21.15	130.04	3.40
B1 14	B2 50	0.28				
C1 19	C2 45	0.42				
A1 14	A2 35	0.40	0.07	14.88	184.80	4.84
B1 14	B2 50	0.28				
C1 24	C2 40	0.60				
A1 14	A2 35	0.40	0.10	9.87	278.67	7.29
B1 24	B2 40	0.60				
C1 19	C2 45	0.42				
A1 14	A2 35	0.40	0.14	6.94	396.00	10.36
B1 24	B2 40	0.60				
C1 24	C2 40	0.60				
A1 14	A2 35	0.40	0.19	5.36	513.33	13.43
B1 40	B2 24	1.67				
C1 14	C2 50	0.28				
A1 14	A2 35	0.40	0.28	3.55	774.07	20.25
B1 40	B2 24	1.67				
C1 19	C2 45	0.42				

Thank you to Cyber Blue, FRC Team 234, for their assistance in product evaluation and creation of these assembly instructions.



Team 221 LLC.
3950 Groveland Road - Ortonville, MI - 48462
Owner/Operator Anthony Lapp
248.884.3676 - 248.942.5066



Assembly Instructions

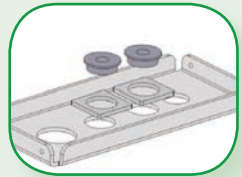

Step 3: Press (2) 3/8" ID Flanged Ball Bearings into middle positions using (2) Bearing Shims as shown. This piece is now called "Inside Gearbox Sideplate".

Step 4: Install (2) Gear Shafts into bearings in Outside Gearbox Sideplate as shown.

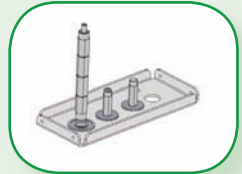
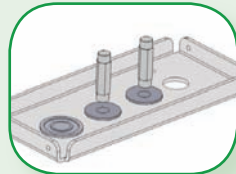

Step 5: Install (1) Drive Shaft into bearing in Outside Gearbox Sideplate as shown.

Step 6a: Install (1) 3/8" ID B2 hex bore spur gear onto Gear Shaft as shown.

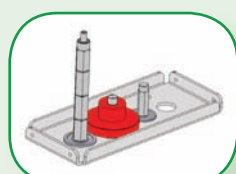

Step 6b: Install (1) 3/8" ID C1 spur gear onto Gear Shaft as shown with step facing up.

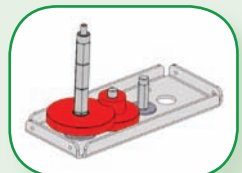

Step 7: Install (1) 1/2" ID C2 hex bore spur gear onto Drive Shaft with step facing up.

Step 8: Install (1) 1/2" Snap Ring into groove on Drive Shaft in position closest to gear.

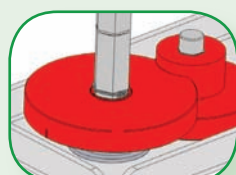

Step 9a: Install (1) 3/8" ID B1 spur gear onto Gear Shaft as shown with step down.

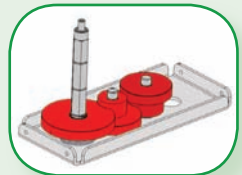

Step 9b: Install (1) 3/8" ID A2 spur gear onto Gear Shaft in position (2) with step up.

Step 9c: Apply spur gear grease to all gear teeth.

Step 10: Install (1) CIM Motor into position (1) of Inside Gearbox Sideplate using (2) 10-32 x 1/2" screws and #10 steel washers. Use caution not to use screws that are too long, as this will cause the motor to lock. Tighten screws.

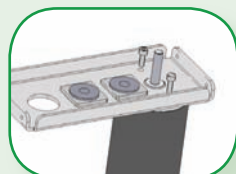

3

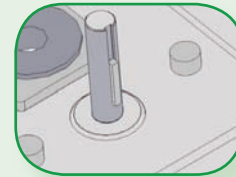

Step 11: Install (1) 3 mm Shaft Key into CIM Motor Shaft.

Step 12: Install (1) A1 spur gear onto CIM Motor Shaft, aligning with key.

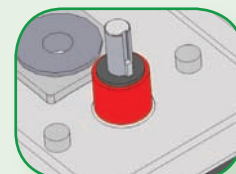
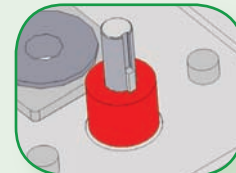

Step 13: Install (1) 5/16" ID Retaining Ring onto CIM Motor Shaft with Retaining Ring Teeth facing away from gear. Drive into gear face.

Step 14: Place Inside Gearbox Sideplate on top of Outside Gearbox Sideplate ensuring Gear Shafts seat in bearings in positions (2) and (3) and 14 tooth gear meshes with 35 tooth gear.

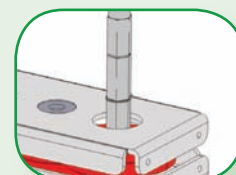
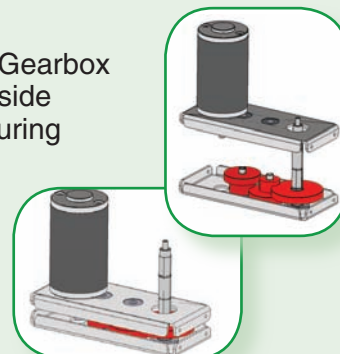

Step 15: Install (1) 1/2" Snap Ring onto next available groove on Drive Shaft.

Step 16: Install (1) Wheel Assembly (SA2) onto Drive Shaft with Wheel Adapter facing down.

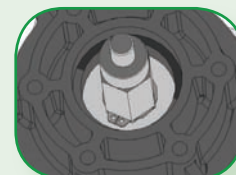

Step 17: Install (1) 1/2" Snap Ring onto next available groove on Drive Shaft.

Step 18: Install (1) 1/2" ID Flanged Ball Bearing into Outside Wheel Mount Plate as shown.

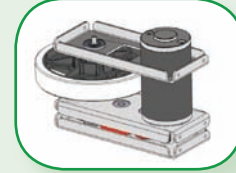
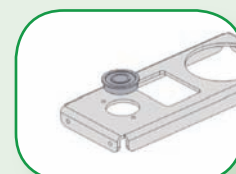

Step 19: Install Outside Wheel Mount Plate onto Gearbox Top Plate, fitting the CIM Motor through the large hole, and seating the Drive Shaft in the 1/2" ID Flanged Ball Bearing.

4

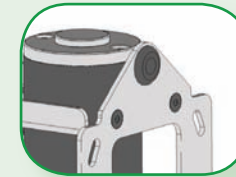

Step 20: Place Rubber Grommet into Gearbox Top Plate.

Step 21: Assemble Gearbox Top Plate onto the Inside Gearbox Plate and the Outside Wheel Mount Plate, passing CIM wires through grommet during assembly. Tighten with (6) 10-24 x 3/8" FHCS.

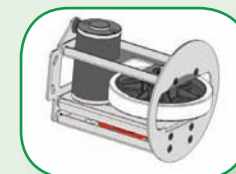
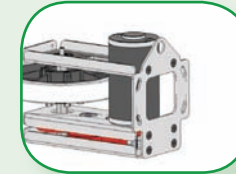

Step 22: Install (1) Rotor onto Outside Wheel Mount Plate, Inside Gearbox Side Plate, and Outside Gearbox Side Plate using (6) 10-24 x 3/8" FHCS.

Sub-Assembly 4 (SA4) : Top System Assembly

Parts Used: (1) Pivot Plate, (1) Pivot Bracket, (1) Plastic Spacer, (1) AM Sprocket, (3) 10-24 x 5/8" FHCS, (3) 10-24 Lock Nut, (1) Pivot Shaft, (1) 1/2" Nut, (1) AM 500 Key Hub, (2) 3/8" ID Bronze Bushing, (4) 10-24 x 3/4" BHCS, (1) 3/8" Snap Ring, (1) AM Sprocket Spacer

Step 1: With the capture nuts facing up, Thread the Pivot Shaft up through the Pivot Plate. Install Nut onto bolt thread as shown. If necessary, place in small vice to allow full seating of the nut.

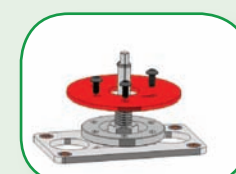
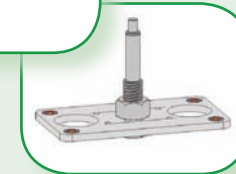

Step 2: Install AM Sprocket Spacer and AM Sprocket to Pivot Plate. Attach with (4) 10-24 x 3/4" BHCS

Step 3: Install Plastic Spacer onto Pivot Shaft

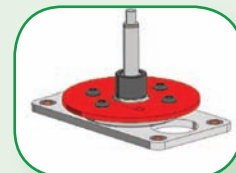

5

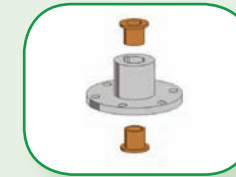

Step 4: Press (2) 3/8" ID x 1/2" long Flanged Bushings onto top and bottom of Drive Adapter as shown. (Depending on fits, these may not need press.)

Step 5: Install Drive Adapter onto Pivot Bracket with (3) 10-24 x 5/8" FHCS. (Note: snug all screws before tightening them all.)

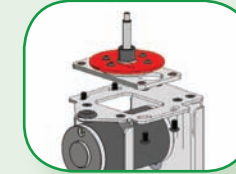
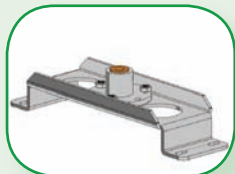

Step 6: Install Pivot Plate on top of Gearbox-Wheel Sub-Assembly (SA3) with (4) 1/4"-20 x 3/8" Button Head Cap Screws.

Step 7: Install Bottom Mounting Plate (SA1) over Gearbox-Wheel Sub-Assembly (SA3).

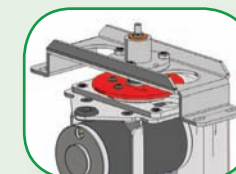
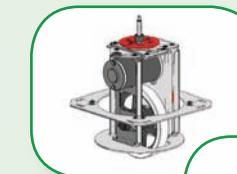

Step 8: Install Top Pivot Bracket over the Pivot Plate.

Step 9: Install 3/8" Snap Ring onto Pivot Shaft.

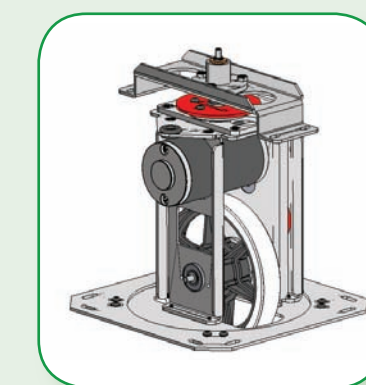
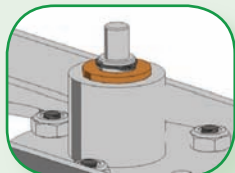

Finished!

6